

### Description

GBR-CRD Ceiling Radiation Damper is UL and cUL listed, and exceeds UL 555C for use in 3-hour fire rated assemblies. GBR -CRD is also Warnock-Hersey certified for use in fire rated floor/ceiling or roof/ceiling assemblies.

### Application

- The GBR-CRD ceiling radiation damper employs a folded curtain style blade for point-of-origin control of radiant heat in a ventilation system
- The GBR-CRD is to be installed horizontally in the ceiling membrane for the floor/ceiling or roof/ceiling assemblies with a fire resistance rating up to and including 3 hours
- Ventilation fans shall be ducted out of the plenum space using any UL 181 Class 0 or Class 1 duct
- UL listed as fan/damper assembly for the following Wood Frame Construction designs: L521, L546, L558, L562, L574, L576, L581, L583, L585, P522, P533, P538 and P545
- Available for Delta Breez Ventilation Fans: GBR50, GBR50L, GBR80, GBR80H, GBR80HL, GBR80HLED, GBR80L, GBR80LED, GBR80MHL, GBR80MHLED, GBR100, GBR100H, GBR100HL, GBR100HLED, GBR100L, GBR100LED, ELT80-110, ELT80-110D, ELT80-110H, ELT80-110MH, ELT80-110LED, ELT80-110DLED, ELT80-110HLED and ELT80-110MHLED

### Features

- Galvanized steel frame and sleeve
- Folded ceramic curtain blade
- 165°F fusible link
- Size: 8 1/2" x 8 3/4"
- High temperature, non-asbestos, reinforced fiber thermal fabric

### Warranty

- 3-year limited warranty

Information is subject to change without notice or obligation

### Ratings

- UL 555C Fire Resistance Rating: 3 hour (horizontal, for use in 1, 2, or 3 hour rated assemblies)

### Listings

- CSFM listing: 3226-0368:104
- UL 555C listing: R27832
- Warnock Hersey listing #: 101232214SAT-003,-004
- Meets NFPA Standards: 90A and 101
- Meets Building Code Standards: IBC, NBC, NFPA, SBC, and UBC

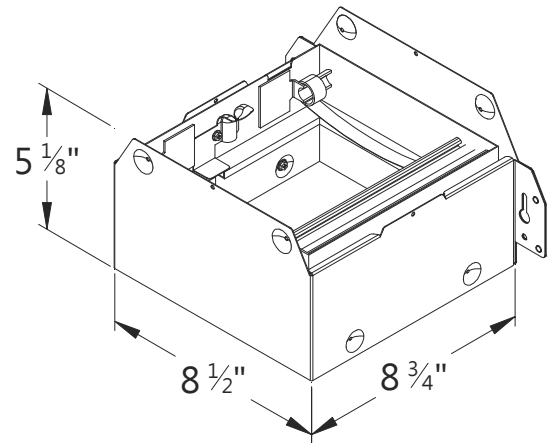
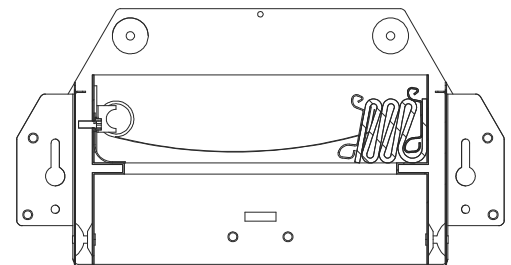

Model	Quantity	Comments	Project:
			Location:
			Architect:
			Engineer:
			Contractor:
			Submitted by:
			Date: